



ADVANCED SCREED CONTROL FOR ASPHALT PAVERS



The industry standard screed control that's simple-to-use and completely compatible:

SYSTEM FIVE AND SMOOTHTRAC®

- PLUG-AND-PLAY COMPONENTS LET YOU WORK THE WAY THAT BEST FITS YOUR APPLICATION
- CONTROL MATERIAL USAGE WITH CONFIDENCE
- COMPATIBLE WITH PREVIOUS GENERATION SYSTEM FOUR AND NEXT GENERATION 3D MC SYSTEMS

SMOOTHTRAC®

- ASSEMBLES IN MINUTES AND FOLDS UP NEXT TO THE PAVER
- NON-CONTACTING MEANS VERSATILITY: IN AND OUT OF BRIDGE DECKS, OVER JOINTS AND CURBS, TURN AROUND, EVEN BACKUP, WITHOUT REMOVING THE SKI!

Paver System Five

Topcon's System Five is the industry's premier grade automation for asphalt pavers. No more cranking, System Five takes care of it automatically.

Paver System Five is easy to configure to best fit each job, choose from sonic elevation control and slope control for roads, or laser and slope for airport runways and parking lots. Or use dual sonic trackers or laser receivers to match an existing surface in road maintenance or widening applications.

Installation is fast. Brackets for two Control Boxes, a slope sensor plate, and Sonic Tracker/Laser Receiver mounting brackets are all that is required, and interfacing to the paver is as simple as connecting a cable to a manufacturer provided interface.

Smoothtrac® Sonic Averaging System

Get the best of both worlds... the superior mat of an averaging ski, the flexibility of sonics.

Replace your traditional drag ski and eliminate the time and hassle spent setting up and tearing down with the convenience and simplicity of Topcon's Smoothtrac® sonic ski. Smoothtrac is made of lightweight aluminum. It mounts in minutes and breaks down to three 8' sections that fit easily in a truck bed.

Smoothtrac utilizes four Sonic Tracker II® non-contacting sensors working in unison to provide superior averaging results while eliminating the cleaning and repair inherent in traditional skis. And unlike traditional contacting skis that can only average based on their mechanical contact with the ground, Smoothtrac adds additional electronic averaging to further smooth the ride. Plus with Smoothtrac, you can back-up, turn around, even pave around curves without removing the ski. And when not in use it folds up and out of the way.

Simple, fast, and economical, that's System Five, that's Smoothtrac, and that's Topcon. It's time.



Paver System Five/Smoothtrac®
Advanced Screed Control for Asphalt Pavers

 **TOPCON**
It's time.

The World's most advanced, easy-to-use operator interface, and durable, time-tested components. No wonder it's the industry standard!...



System Five Control Box

- Large, backlit grade LCD
- Bright, multi-color LED's display continuous grade information
- Simple push button switches and grade knob operation
- Performance settings with secure access allows custom valve response tailoring for optimum performance for your paver
- Upgradeable flash memory from a PC or laptop, in the office or in the field



Sonic Tracker II®

- High-resolution sonics for application versatility. Use references such as: elevated stringline, surface string, poured curbs, or existing surface
- Rugged cast housing with completely sealed internal electronics
- Easy to attach and position over reference
- Bright grade indication LED's display continuous grade information

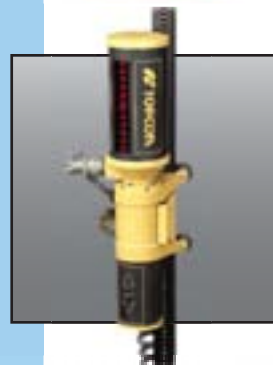

9130 Laser receiver

- 360° gapless receiving
- Motorized trackerjack gets receiver on-grade quickly and "locks-on" to keep it there
- Bright grade indication LED's display continuous grade information
- Compatible with all Topcon lasers and most other lasers



Slope sensor

- 100% slope capable
- Exclusive anti-slosh ceramic technology
- Completely sealed internal electronics
- Rugged cast housing

Feeder control that makes sense

Topcon's Sonic Feeder Sensors feature an environmentally sealed body and field replaceable transducer. Two models to choose from, auto controlled for machines with auger control interfaces and switch controlled for pavers without interface boxes.

Make the next time you replace a feeder sensor due to fouling the last time, switch to Topcon's Sonic Feeders. Experience cost effective feeder control that makes sense.



System Five

Whether setting up on a new job or pulling off the blocks to start another day, you'll realize System Five productivity from the moment you turn it on...

Proven to enhance rideability

System Five removes the stabbing and cranking that causes scalloping and uneven mat.

Superior material control

Calculate exactly the amount of material you'll need. Because of System Five's consistency, calculate compaction and the number of lifts to reach final mat thickness to extreme accuracies.

Increase production rates

System Five's accuracy and reliability means you can work at higher speeds, reduce starts and stops, and get the job done on time and within budget.

Superior compatibility

Paver System Five is compatible with all major models of asphalt pavers – no hydraulic or electrical modifications necessary.

Smoothtrac[®]

Topcon's Smoothtrac[®] Sonic Averaging System – the best of both world's - superior averaging, maneuverability, and productivity - without the drag of a traditional ski

Versatility beyond any ski you've ever used...

For the first time, enjoy the advantages of a ski without sacrificing speed and maneuverability. In a tight spot? Remove Smoothtrac then re-attach, it only takes a few minutes. Or better yet, simply fold the Sonic Tracker II's up and out of the way. You can even fold the front and rear Smoothtrac arms to reduce the length to 1/3 size. Then when you're ready to pave again, simply unfold and go.

Smoothtrac performance? We've got proof!

Here's a portion of a state certified longitudinal section profilograph. Though milling was recommended (shown in red), none took place.

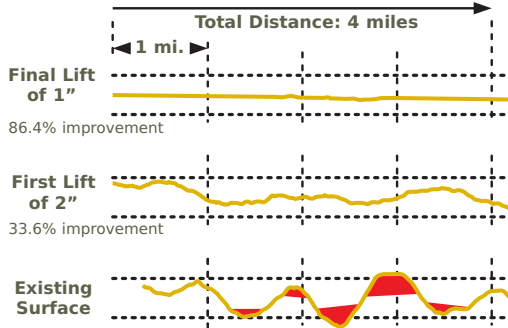

Information is based on data gathered using a state certified profilograph. Because profilograph systems, materials, and conditions differ by region, your results may vary.

Paver System 5 utilizes patented technology to increase mat quality and control materials to the highest levels possible. Here's how it works:

Sonic Tracker II[®]

The Sonic Tracker II sends out a "packet" of sound pulses 39 times per second. Upon striking a reference (stringline, curb, existing surface, etc) these sound pulses produce an echo that travels back to the Sonic Tracker II. By calculating the time it takes for the sound wave to leave and the echo to bounce back, the Sonic Tracker II calculates the distance to the object.

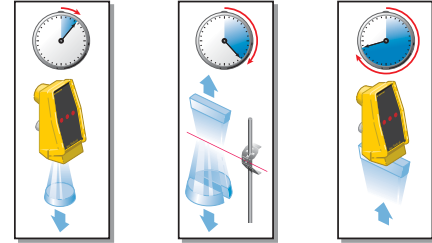

Sound travels through warm air faster than cooler air, so a "bail" is used to create a distance "constant" so the Sonic Tracker II can adjust for temperature fluctuations common in the vicinity of a hot screed.

To go to work, simply place the Sonic Tracker II over your reference and pave. The Sonic Tracker II will maintain a consistent distance over a reference sending signals to the hydraulic valves creating a perfectly smooth mat based on your reference.

9130 Laser Receiver

The 9130 Laser Receiver locks on to the beam of your laser to maintain grade. Simply set the 9130 on the trackerjack pole and center on the beam. When you begin paving, the 9130 will work with the paver's hydraulic system to move the screed up or down to keep the beam "on-grade" and delivering a smooth, consistent mat.

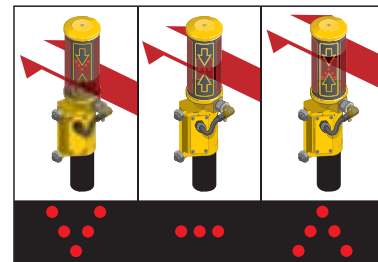

Smoothtrac sonic averaging system

Topcon's Smoothtrac sonic averaging system incorporates five Sonic Tracker II's with a 24' aluminum ski to create superior averaging over traditional skis measuring 40' or more. The Sonic Tracker II's, working together, continuously measure the elevation over a surface, automatically averaging the high points against the low points and adjusting the screed to a mid-point.

System Five consists of...

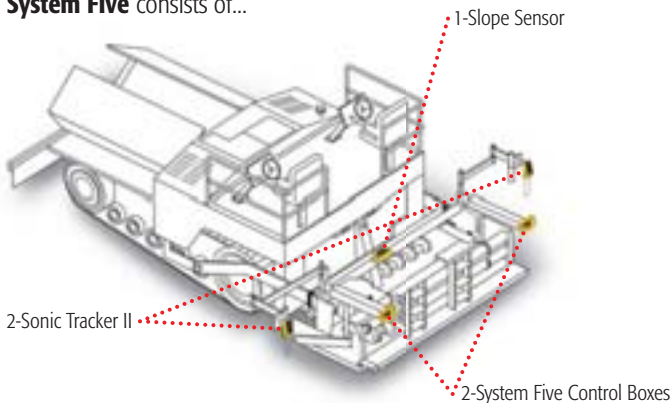

System Five with Smoothtrac[®] consists of...

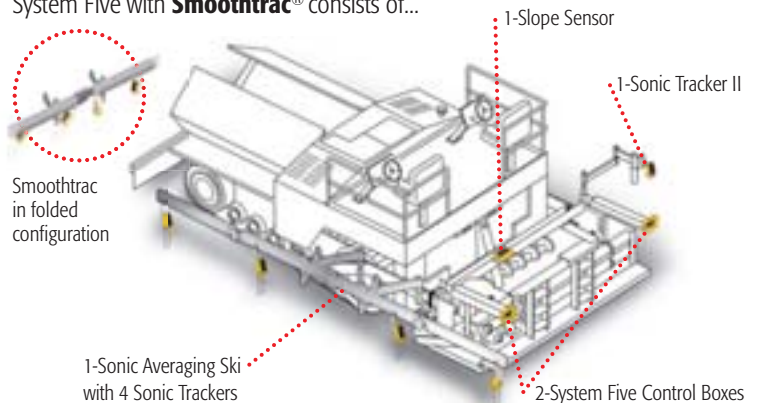

The Leader in Positioning Technology...

Topcon offers positioning products that deliver unparalleled site-wide performance and integration. Topcon's history of technological advances and our reputation for superior reliability means there's no other company positioned to provide you with a better "Total Positioning Solution."

From survey to inspection Topcon, through our 170+ dealers throughout North and South America, provides the innovative technology that gives surveyors, civil engineers, contractors, equipment owners, and operators the competitive edge by addressing such critical issues as increasing profits, quality craftsmanship, improving productivity, lowering operating costs, and enhancing job site safety.

Full positioning integration field-to-finish: That's the goal of Topcon. When it's time for you to step up to the next level, it's time to turn to Topcon.

The Leader in Customer Satisfaction...

To ensure that your Topcon product maintains peak performance, your local Topcon dealer offers factory trained and certified service technicians. If service isn't available in your area, our factory offers a repair and return policy second to none.

Offices Worldwide

TOPCON CORPORATION

75-1 Hasunuma-cho, Itabashi-ku • Tokyo 174-8580, Japan
Phone: 3-3558-2520 • Fax: 3-3960-4214 • www.topcon.co.jp

Topcon Europe Positioning B.V.

Essebaan 11, 2908 LJ Capelle a/d IJssel • THE NETHERLANDS
Phone: 010-4585077 • Fax: 010-4585045 • www.topconeurope.com

Topcon Corporation Beijing Office

Block A No.9, Kangding Street, Beijing Economic
Technological Development Area, Beijing 100176 • CHINA
Tel: +86-10-6780-2799 • Fax: +86-10-6780-2790



Topcon Positioning Systems, Inc.

7400 National Drive
Livermore, CA 94550
www.topconpositioning.com



Specifications subject to change without notice

©2006 Topcon Corporation All rights reserved.

P/N: 7010-0131 Rev. F Printed in U.S.A. 04/07

mmGPS Paving - Only from Topcon!

The next generation of asphalt paver control – and Paver System Five and Smoothtrac® are fully upgradeable. mmGPS - from the innovators in asphalt paver automation!...

Imagine controlling your paver right from digital site plans. As you pave you're producing exact thickness at exact slope automatically. No following stringlines, curbs, or other surface references.

At the heart of Millimeter GPS™ is Topcon's Lazer Zone™ technology. This revolutionary technology brings together the simplicity of a rotating laser, the accuracy of a robotic total station, and the flexibility and multiple user capabilities of GPS into one complete jobsite solution! Topcon combines this revolutionary new transmitter with the PZS-MC receiver and Topcon's 9168 Control Box and slope sensor to create a system that's changing the face of paver automation. Here's how it works:



PZL-1

Positioning Zone Laser Transmitter operates similar to a standard rotating laser, but transmits a unique Lazer Zone™ signal to provide a working range of 2000ft! Instead of a traditional flat plane, the PZL-1 provides an incredible measuring area of 33ft in height! You can even link up to four laser transmitters for use on large sites to cover a distance of nearly 8000ft with elevation changes of over 130ft! No more taking time out to reposition your laser. With the PZL-1, multiple machines can use the same transmitter, even at different elevations for continuous production!



PZS-MC

The PZS-MC (Positioning Zone Sensor – Machine Control) mounts to your paver in the same manner as traditional laser receivers. Unlike traditional laser receivers, the PZS-MC knows its exact position within the 33' vertical working range of the PZL-1 at every moment. With its integrated GPS antenna, the PZS-MC antennas continuously and accurately provide elevation and horizontal position information to the Control Box containing the digital site plans.



Knowing where the paver is located within the digital site plan, and knowing the grade required at that exact position, the control box sends correction signals to the screed to precisely maintain mat thickness and slope for that position on the site. And mmGPS is fast, continuously updating position and grade information so you work as fast as you want.

Ask your local Topcon Dealer for more information on mmGPS.

Topcon offers a full range of Machine Automation systems, Construction Lasers, Survey Optical Instruments, and GPS Instruments for all of your positioning needs. Contact your local Topcon Dealer for more information.

Topcon. It's time.

Your local Authorized Topcon dealer is: